

UDK 621.924.7

DEVELOPMENT OF THE FOUR-LINK HINGED MECHANISM OF BARRELING MACHINE DRIVE

M.G. Zalyubovskiy, Doctor of Technical Sciences, Professor
Open International University of Human Development "Ukraine"

I.V. Panasyuk, Doctor of Technical Sciences, Professor
Kyiv National University of Technologies and Design

Keywords: spatial mechanism, kinematic pair, connecting rod, slider.

Performing analytical studies [1] using CAD Solid Works, we will design a machine drive with an oscillating crank gear mechanism that implements the law of change in the angular velocity of the driving shaft. The kinematic scheme of the barreling machine that has a special drive is presented in Fig. 1.

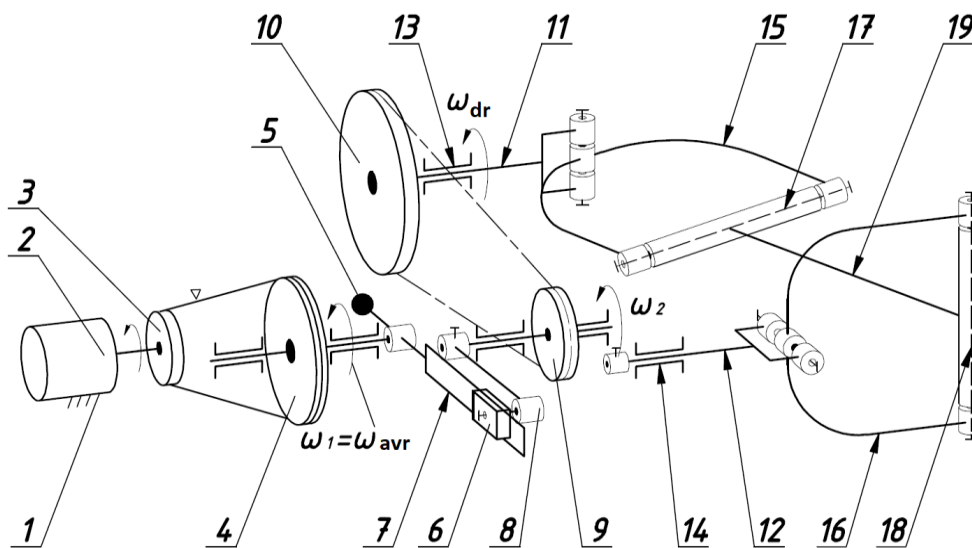

Figure 1. The hinged component of the machine drive

The machine contains frame 1 in which there is electric motor 2 driving pulley 3 of the belt transmission is fixed to its shaft; driven pulley 4 is connected to drive crank gear 5 of the oscillating crank gear mechanism; slide block 6 that moves along guide 7 of crank gear 5 has a kinematic link to driven crank 8 that is also connected to driving sprocket 9 of the chain transmission; driven sprocket 10 is fixed on drive shaft 11 of the machine. Driving 11 and driven 12 shafts are fixed in bearings 13 and 14, respectively, and are connected to forks 15 and 16, respectively; diametrically mutually perpendicular axes 17 and 18

of the forks are the axes of attachment of container 19; ω_{dr} is the angular velocity of the driving shaft; ω_2 is the angular velocity of the driven crank; ω_1 is the angular velocity of the driving crank; ω_{avr} is the average value of the law of change in the angular velocity of the driving shaft.

Let us synthesize the oscillating crank gear mechanism that is part of the drive while ensuring efficient ratios of the lengths of its links in order to implement the law of change in angular velocity [2]. Let us design a kinematic diagram of the crank gear mechanism with link sizes chosen arbitrarily in 12 positions. The diagram is presented in Fig. 2.

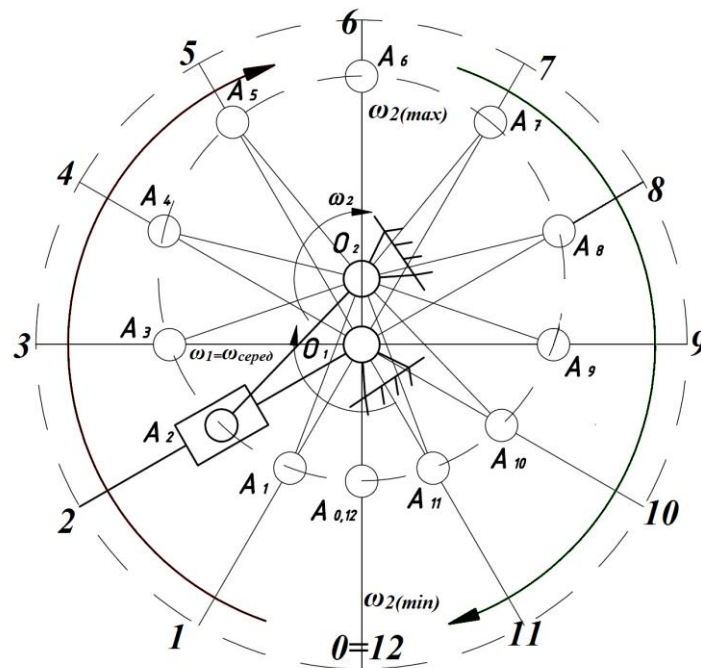

Figure 2. Component that is kinematically connected to the chain drive

The mathematical dependences for calculating the main design parameters of the hinge drive component have been obtained analytically. The influence of the design parameters of the four-link hinge crank gear mechanism on the law of change in the angular velocity of the driven crank has been established. The obtained results can be used by design offices of relevant machine-building enterprises at the stage of designing barreling machines.

The mathematical dependences for the calculation of the basic structural parameters of the hinged component of the drive for keeping the pressure angle in the mechanism kinematic pair within the permissible limits have been obtained. Thus, we derive the expressions for determining the pressure angle in the kinematic pair A:

$$\Theta = \arcsin(l_{O_2A} \wedge l_{O_1A}) = \frac{l_{O_1O_2} \sin(l_{O_2O_1} \wedge l_{O_1A})}{l_{O_2A}}. \quad (1)$$

The obtained results enable implementing new configurations of the equipment.

References

1. Zalyubovskiy M. G. Design parameters of the four-link hinged mechanism of barreling machine drive / M.G. Zalyubovskiy, I.V. Panasyuk, S.O. Koshel', D.O. Lychov // International Applied Mechanics, 58, No. 6, November 2022, 725 – 731;
2. Zalyubovskii M. G. Modeling and designing the barreling machine drive with complex spatial motion of the container / M.G. Zalyubovskii, I.V. Panasyuk, S.O. Koshel', G.V. Koshel' // International Applied Mechanics, 58, No. 4, July 2022, 472 – 480.